

# Video Security



## VHM/DP-ECL

Dustproof Housing (330mm), RAL7032

Art-No. 79366



## Features

### Camera Protection

Housing Body Length: 330mm

Fold-down Housing Body

4 Levels of Camera Height Adjustment

Insulated Camera Mounting

### 3 Cable Entries

Viewing Screen with "Clear-Shield" Technology

Incorporated Carrier Handle

Housing Surface: RAL7032

Option: Cable Distributor Board

## Specifications

Maximum installation length	330 mm
Length for power supply	NE-112 (1 output): 85 mm; NE-112/2 (2 outputs): 110 mm
Cable entries	M16 x 1.5mm
Window screen	Coated with "Clear Shield" Technology. With this technology the glass corrosion, caused by environmental pollution, is avoided and screen cleaning cycles will be extended. The coating is UV light resistant, colour neutral and it causes no F-stop loss.
Window heater	None
Sunshield	None
Housing	Aluminium w. plastic end caps
Colour	RAL 7032
Protection rating	IP 66
Parts supplied	Screw set
Dimensions (HxWxD)	See drawing
Weight	1.9 kg

## Accessories

<b>73064 / WD-16/MK</b>	Wall Mount with Swivel Head for VHB/VHM Weatherproof Housings, RAL7032
<b>79491 / NE-112/AC24V</b>	Power Supply Unit 230VAC/24VAC (600mA) for VHM Housing
<b>79364 / NE-112</b>	Power Supply Unit 230VAC/12VDC (600mA) for VHM Housing, Regulated
<b>79423 / NE-112/2</b>	Power Supply Unit 230VAC/12VDC (600mA), Regulated, 24VAC (1000mA) f. VHM Housing
<b>79623 / VHM/PC-1</b>	Plug-in shield for VHM/EC&ST Housing Series, 330mm
<b>79627 / VHM/KV2</b>	Cable Connection Board with Thermostat for VHM Housing, "EC" Series

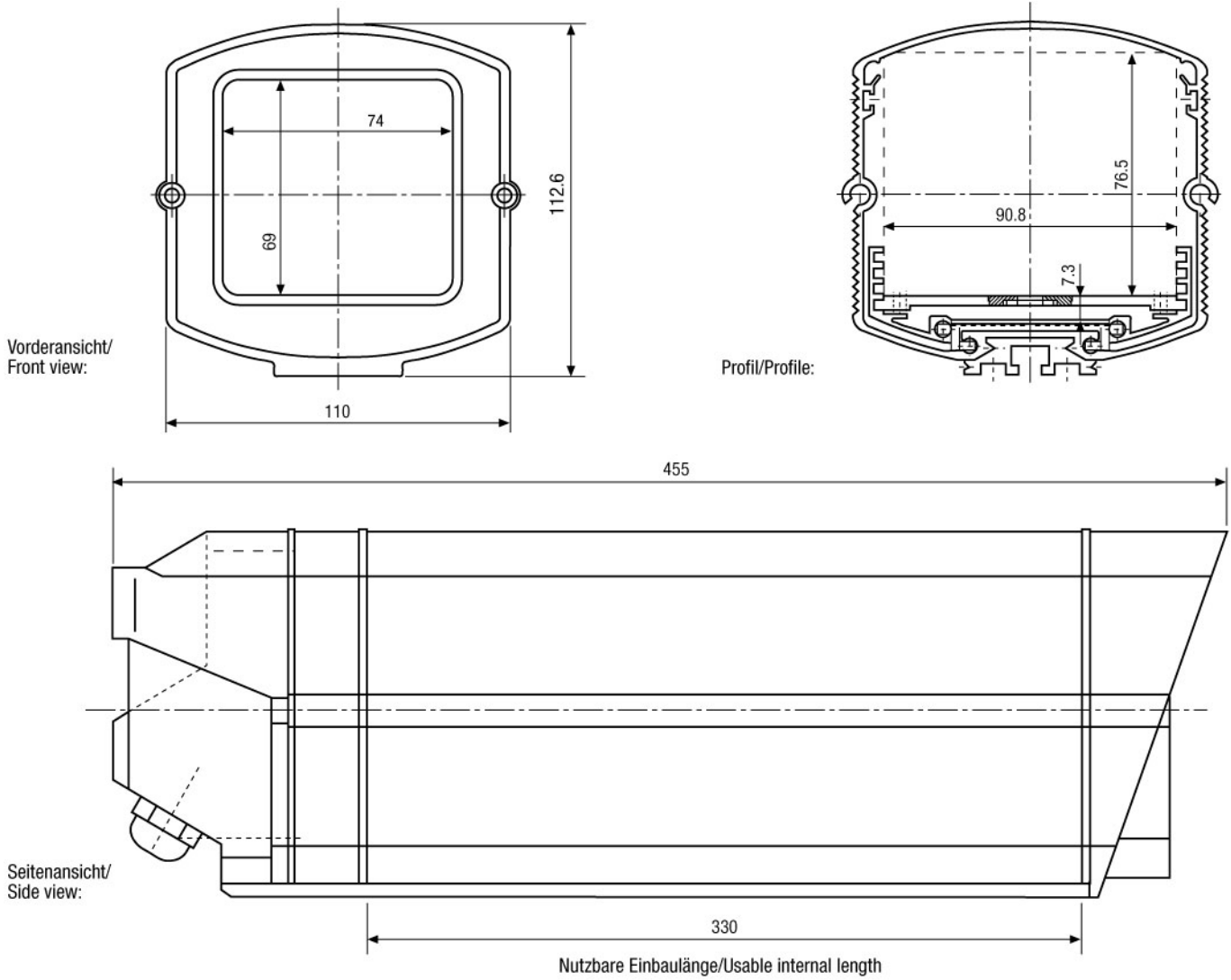

Maße/Dimensions: mm

CamTech Industriel Video ApS  
 Your Contact: Sales Department  
 Industriparken 4 · 2750 Ballerup  
 Phone +45 44 68 02 67 · Fax +45 44 68 60 52  
 info@camtech.dk · www.camtech.dk